

PERFORMANCE SPECIFICATIONS

GPS RECEIVING UNIT

MODEL: CCA-550JZ1

Preliminary

Sep.30, 2004

JRC *Japan Radio Co., Ltd.*

INDEX

1. COMPONENTS LIST	3
2. RECEIVING UNIT SPECIFICATIONS.....	3
2.1 GENERAL	3
2.2 I/O CONNECTOR PIN FUNCTIONS	4
2.3 RF CONNECTOR.....	4
2.4 CSF(Cold Start Fix) Starting Term	5
2.5 OUTLINE DRAWINGS.....	6
3. RECOMMENDED ANTENNA	7
4. WIRING DIAGRAM.....	8
5. NOTICE FOR HANDLING	9
5.1 Maximum Rating	9
5.2 Caution for Installation	9
5.3 Notice for Storage.....	9
5.4 Transportation.....	9
5.5 Overcurrent Protection	9

1. COMPONENTS LIST

Item	Type	Qty	Remarks
Receiving Unit	CCA-550JZ1	1	

2. RECEIVING UNIT SPECIFICATIONS

2.1 GENERAL

Receiving Method:	Multi-channel(Receiving:13channels,Special search:1 channel)
Receiving Frequency:	1575.42MHz (L1), C/A code
Sensitivity:	-135dBm (at NAY-3700S5 antenna receiving level)
Dynamic Range:	25dB
Fixing Method:	ALL IN VIEW
DATUM:	WGS-84 (default, 46 datums selectable)
Accuracy	
Alone	GPS System Accuracy
Position:	10m 2dRMS (SA off, PDOP=2.5, HDOP=1.5)
Speed:	0.04m/sec. RMS (SA off, PDOP=2.5, HDOP=1.5)
Course:	0.14 ° (SA off, speed = 60km/h, PDOP=2.5, HDOP=1.5)
DGPS	
Position:	7m 2dRMS (example)
Dynamic Capability	
Maximum Velocity:	200km/h
Maximum Acceleration:	19.6m/s ²
Time To First Fix (no signal loss)	
HOT START:	8sec. typical
WARM START:	33sec. typical
COLD START:	40sec. typical
Re-acquisition Time:	3sec. (within 5 sec. block out)
DGPS Capability:	RTCM SC-104 version 2.1, 1200bps (Type 1,2,9)
Position Fix Data Output Rate:	1sec.
Data I/O	
Interface:	CMOS level (3.3V)
Output:	TXD0 4800bps (Position Data Output)
Input:	RXD0 4800bps (Initial Setting Data Input) RXD1 1200bps (DGPS Correction Data Input)
Data Output Format:	NMEA Format 2.20
Power Requirements	
Main Power:	Vcc: +3.3Vdc ± 5%, 100mVp-p ripple (max.)
Consumption Current:	Icc: 88mA typical (+3.3Vdc, 25 °C), except for antenna (T.B.D) 95mA max. (+3.465Vdc, 70 °C) (T.B.D)
Backup Power (SRAM&RTC):	Vbu: +2.2 to Vcc Vdc
Consumption Current:	Ibu: 5 μ A typical (+3.3Vdc, 25 °C) (T.B.D) 90 μ A max. (+3.465Vdc, 85 °C) (T.B.D)
Input Power for Active Antenna:	Vant: +3.0 to +5.25Vdc
Consumption Current:	Iant: 5 to 30mA
Incorporated Battery:	No
Connectors	
RF Connector:	UM-QPJ-FHSB-1 (Hirose)
I/O Connector:	MA44-10PA-SH(70) (Hirose)
Size:	19mm(H) × 27mm(W) × 7.5mm(D)
Weight:	13g (approx.) (T.B.D)
Temperature	
Operating:	-30 to +70
Storage:	-40 to +85

2.2 I/O CONNECTOR PIN FUNCTIONS

PIN No.	PIN NAME	DESCRIPTION	PARAMETER	TEST CONDITIONS	VALUE			UNIT	
					MIN.	TYP.	MAX.		
2	PPS	PPS Output	Output Level High (V _{OH})	I _{OH} =-8mA	V _{CC} -0.4		V _{CC}	V	
			Output Level Low (V _{OL})	I _{OL} =8mA			+0.4		
3	Vbu	Backup Power Input	Supply Voltage (Vbu)	Vbu Vcc	+2.2	+3.3	Vcc	Vdc	
			Supply Current (Ibu)	Vbu=+3.3V, 25		5 (T.B.D)			μA
				Vbu=+3.465V, 85			90 (T.B.D)		
4	TXD0	Position Data Output	Output Level High (V _{OH})	I _{OH} =-8mA	V _{CC} -0.4		V _{CC}	V	
			Output Level Low (V _{OL})	I _{OL} =8mA			+0.4		
5	RXD0	Initial Setting Data Input	Input Level High (V _{IH})		2		V _{CC} +0.3	V	
			Input Level Low (V _{IL})		-0.3		0.8		
6	Vcc	Main Power Input	Supply Voltage (Vcc)		+3.135	+3.3	+3.465	Vdc	
			Supply Current (Icc)	Vcc=+3.3V, 25		88 (T.B.D)			mA
				Vcc=+3.465V, 85			95 (T.B.D)		
7	Vant	Active Antenna Power Input	Supply Voltage (Vant)		+3.0		+5.25	Vdc	
			Supply Current (Iant)		5		30		mA
8	RXD1	DGPS Correction Data Input	Input Level High (V _{IH})		2		V _{CC} +0.3	V	
			Input Level Low (V _{IL})		-0.3		0.8		
10	GND	Ground							

Pin No.1 and No.9 shall be left open.

2.3 RF CONNECTOR

NAME	PARAMETER		VALUE		UNIT	REMARKS
			MIN	MAX		
RF CON-NECTOR	AC	Nominal Impedance	50			
		VSWR		2.2		@f=1575.42 ± 1MHz

2.4 CSF(Cold Start Fix) Starting Term

- 1)When a RAM error is detected in the RAM pattern check that has been conducted at powering on.
- 2)When an RTC read error is detected.
- 3)When power has been turned on and off in the patter shown in Figure.
- 4)When the CSF start command is used for turning the CSF on.
- 5)When the Fail-safe function have detected an abnormal state of the GPS receiver.

** Fail-safe function **

If the non-positioning state continues for ten minutes, one of fifteen channels is assigned to PCSF (Partial Cold Start Fix) function, and other than satellites can be searched. If GPS receiver detected an abnormal state during PCSF operation, this is regarded as an impossible event, and the CSF is started.

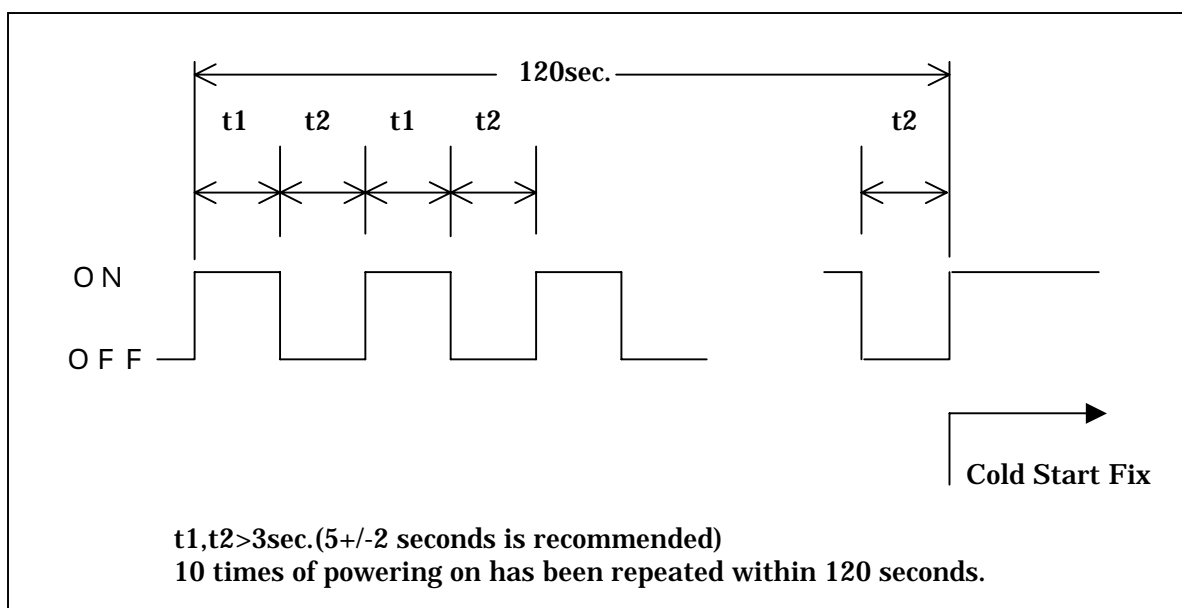

When the CSF has started, latitude, longitude and altitude and control parameters (DATUM, Smoothing level, output format, etc) will be reset to indicate the default values, and time data will be also reset to indicate "00 (Y) 1(M) 1(D) 00 (H) 00 (MIN) 00 (SEC)". Therefore, when you use the GPS receiver at different values of the parameter from the default value, you need to reset your values again.

2.5 OUTLINE DRAWINGS (T.B.D)

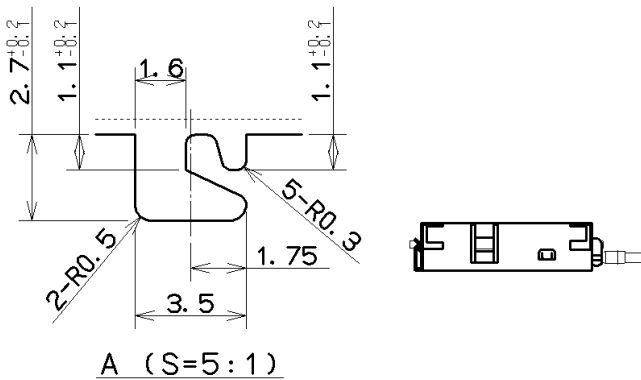

Tolerance	
Classification	Tolerance
0 to 30	±1
Over 30 to 120	±1.5

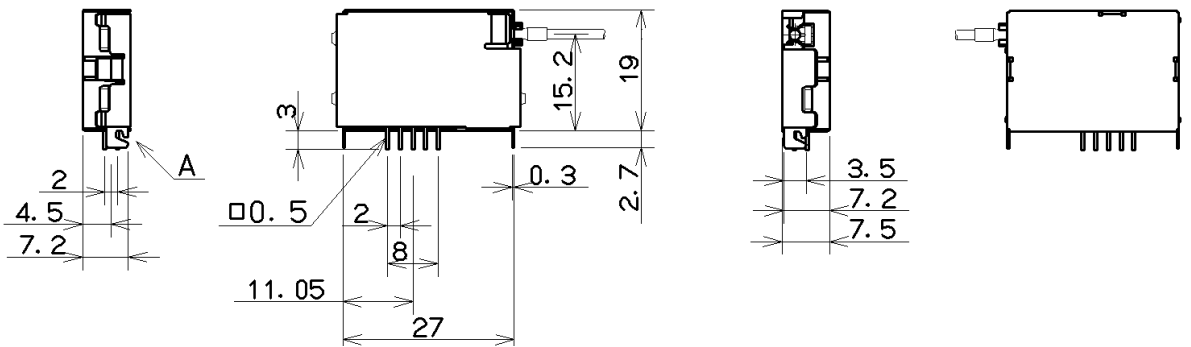

I/O CONNECTOR
MA44-10PA-SH(70)

UM CONNECTOR
UM-QPJ-FHSB-1

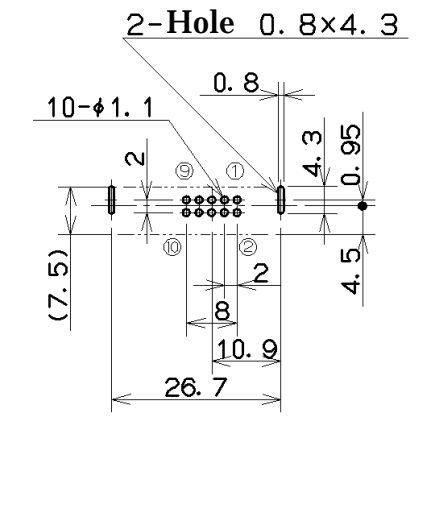
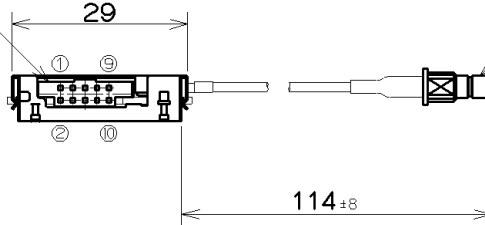

I/O Connector Pin

Pin No.	Pin NAME
1	NC
2	PPS
3	VBU
4	TXD0
5	RXD0
6	VCC
7	VANT
8	RXD1
9	NC
10	GND

Unit : mm

3 RECOMMENDED ANTENNA

Recommended Antenna:	NAY-3700S5
Type:	Active
Overall Performance (Antenna+LNA+Cable)	
Gain:	16dBi min. (Elevation=90 Degrees, -30 ~ +85)
Output Impedance:	50
VSWR:	2.0 max.
Power Source:	3.0 ± 0.3V
Current consumption:	Less 17mA
RF Connector:	SMB Plug
Antenna Part[Following specification in defined in case the Gound plane(65mm × 65mm) is fitted]	
Gain Coverage:	2 dBi min. (Elevation=90 Degrees) -5dBi min. (Elevation=10 Degrees)
Polarization:	RHCP
Axial Ratio:	4.0dB max. (Elevation=90 Degrees)
Low Noise Amplifier (LNA) Part	
Power Gain:	20dB min.(-30 ~ +85),Exclude cable loss
Noise Figure:	2.0 dB max.(-30 ~ +85)
Receiving Frequency width:	1575.42 ± 1.023MHz
Out of Band Rejection:	20dB min.(at 1575.42MHz ± 50MHz)
Cable:	1.5D Coax. Cable , 5m long

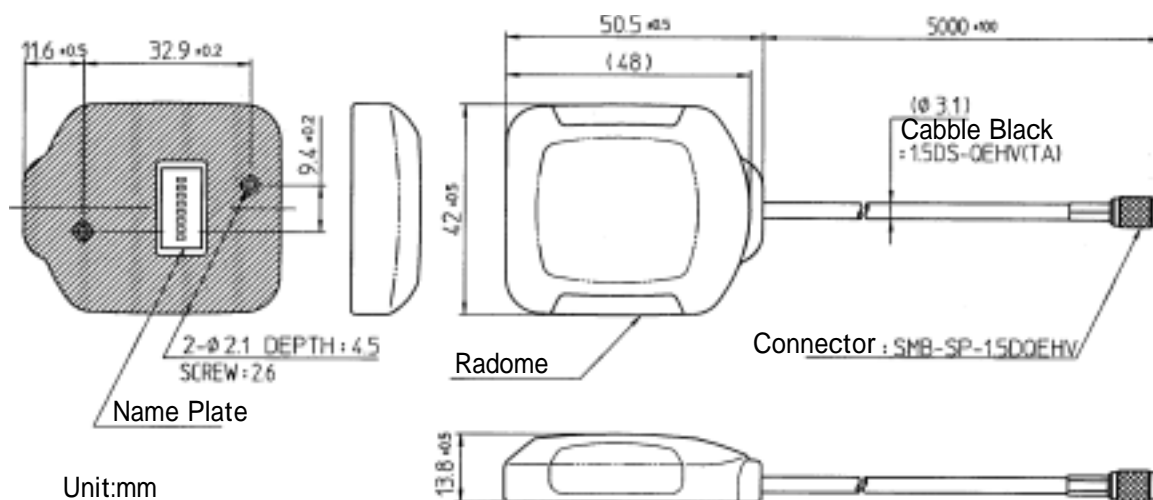

Unit:mm

Tolerance

(Unless otherwise specified): ± 0.3

NAY-3700S5 OUTLINE DRAWINGS

4 WIRING DIAGRAM

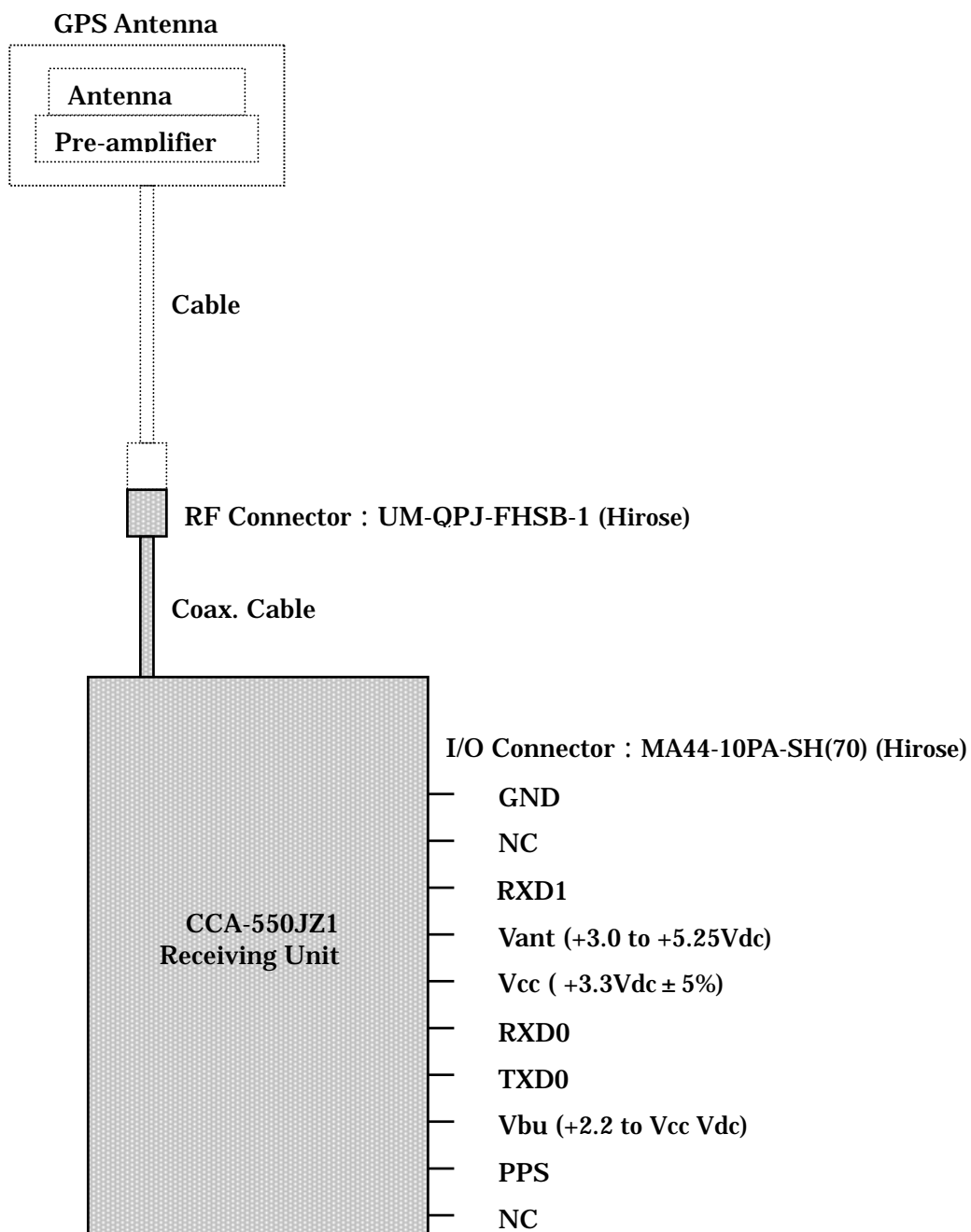

Pin # and shall be left open.

5 NOTICE FOR HANDLING

5.1 Maximum Rating

Do not use over maximum rating because if use over maximum rating it is doubt become the fault.

1)Power Voltage :Vcc

Maximum voltage

It is regulated maximum voltage which conpermit input voltage between input terminal and GND.

Once over the maximum voltage is inputted, it is become the reason of faulty.

2)Input Voltage

It is regulated maximum voltage to input terminal.

Once over the maximum voltage is inputted, it is become the reason of faulty.

3)Operating Temperature

It is the temperature rang which can have a guarantee for operating corestly.

Once over the temperature rang it is become the reason of faulty or it is doubt that can not have the satisfy of the function of GPS.

4)Storage Temperature

It is the temperature range which unit is strong in case storage temperature is over this temperature rang, it is become the reason of faulty or it can not have a satisfy of the function.

5.2 Caution for Installation

In case handle with this unit, be careful against a static electricity.

It is not that unit will be damaged by a static electricity.

Specially, handle with I/O connector, be careful against a static electricity.

Do not touch the RF connector and I/O connector dirty with hand.

5.3 Notice for Storage

1) Do not storage the place where corrosion gas will be generated or exist many dusts.

2) Do not storage the place where temperature rang will be change widely because the dewdrop will be formed therefor.

5.4 Transportation

1) Do not throw,do not drop,otherwise unit itself will be damaged.

2) Protect from water,when transport in the rain/snow,protect from them.

5.5 Overcurrent Protection

GPS Receiving Unit dose not have a fuse for overcurrent protect.

Please put a fuse for overcurrent protect in your system because the prevention of danger.